

# A r c h i t e c t u r a l   S q u a r e s

Job Name \_\_\_\_\_

Type \_\_\_\_\_

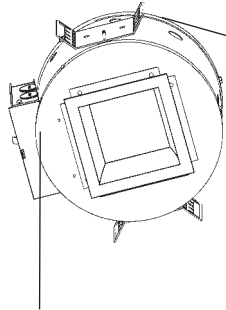

Adjustable height electrogalvanized plated steel mounting ears with cutouts for various mounting methods. Standard bars (included) are innovative and incorporate rigid formed cross sections, joist positioning tabs, integral nails, auxiliary nailholes, T-Bar slots and holes for locking bars to T-Bar using #8 self-tapping screws (by others). Bars extend 14"-24". Ears will also accept Caddy Bar #520 for fast installation in T-Bar ceilings, bars extend 27".

**6"x6"  
LOW VOLTAGE  
ADJUSTABLE  
SQUARE**

Electronic 75VA 120V or 277V primary, 12V secondary. Removable from below. *UL Listed* component.

Heavy gauge electrogalvanized steel junction box, prewired and grounded with easy access from below. Listed for through branch circuit wiring.

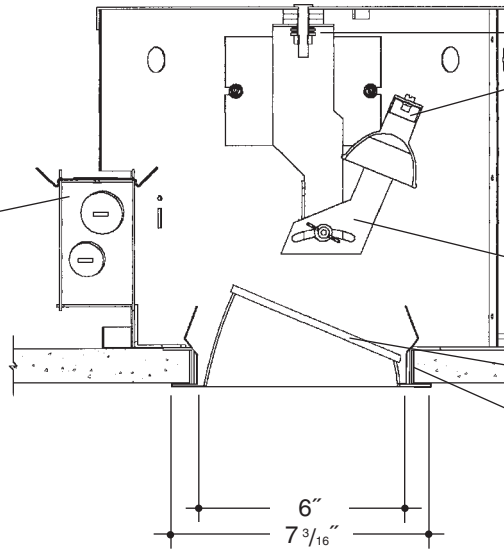
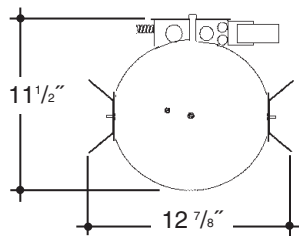

*UL Listed* socket with 450°C high temperature leads. Lamp holder designed to accept several different types of lens accessories, clear tempered lens standard. (See Options)

Steel housing wrap with interlocking seams for strength and vents for cool operation. Aluminum housing cap also transfers heat for maximum lamp life. Top relampable.

Positive locking, adjustable yolk assembly 45° vertical and 350° horizontal adjustment.

Square "Alzak" aperture trim, angle cut, die formed, mitred corners, self trimming flange and positive spring retention clips.

Integral 3/4" plaster frame.

## Rough In Kit – 6" x 6" Square Low Voltage Adjustable (75W MR16; 50W MR16)

Catalog Number **VGS66ADJ-LV-MR16**

**VGS66ADJ-LV-MR16**

Wattage

Transformer

Voltage

Options

75W MAX. MR16  
50W MR16

E

1  
2

Transformer  
E Electronic  
Voltage  
1 120 Volts  
2 277 Volts  
Options ▲

## Must Specify Lamping

## Finishing Kit – 6" x 6" Square Angle Cut Open Reflector

Catalog Number **VGS6630**

**VGS6630**

Finish

Options

Lamp Lens Options

SCL  
SGO  
SGC  
ECL  
WHT

PF

14

Finish (Factory Standard)

**SCL** Specular Clear "Alzak" with White Flange  
**SGO** Specular Gold "Alzak" with White Flange  
**SGC** Soft Glow Clear "Alzak" (Semi-Spec) with White Flange  
**ECL** Etched Clear "Alzak" (Haze) with White Flange  
**WHT** White with White Flange

Options ▲

**PF** High Polished Flange

Lamp Lens Options

**14** C73 Lens (Standard)

## Features

Manufactured and Listed to UL 1598, ETL and CSA standards.  
Suitable for Damp Locations  
Wet location under covered ceiling



▲ See Options and Finishes pages for a list of additional finishes and equipment.

Vantage reserves the right to change components, finishes or design details in any manner which does not alter the installed appearance or reduce performance and intended function.

Vantage

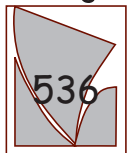

Luminaires

76 Community Avenue Plainfield, CT 06374  
voice (860)564.4512 fax (860)564.4854  
www.vantageitg.com

01/10