

Architectural Squares

Job Name _____

Type _____

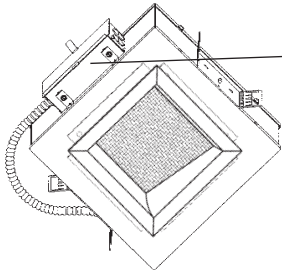

Heavy gauge electrogalvanized steel junction box, prewired and grounded with easy access from below. Listed for through branch circuit wiring.

6"x6" H.F. 1 LT LENSED WALL WASH SQUARE

Electronic ballast, Class P, 50/60 HZ-120/277, Programmed Start, thermally protected, 98% Power Factor, 1.00 Ballast Factor, <10% THD, Class A sound rated. Minimum starting temperature -18°C/0°F. *UL Listed* component.

Precision formed aluminum specular clear low iridescent "Alzak" upper reflector.

Housing is formed of heavy gauge electrogalvanized steel with integral venting for cool operation and extended lamp life.

Adjustable height electrogalvanized plated steel mounting ears with cutouts for various mounting methods. Standard bars (included) are innovative and incorporate rigid formed cross sections, joist positioning tabs, integral nails, auxiliary nailholes, T-Bar slots and holes for locking bars to T-Bar using #8 self-tapping screws (by others). Bars extend 14"-24". Ears will also accept Caddy Bar #520 for fast installation in T-Bar ceilings, bars extend 27".

Aluminum socket housing with quick assembly hardware. *UL Listed* socket and electrical connectors.

Square "Alzak" aperture trim, die formed, mitred corners, self trimming flange and positive spring retention clips. Integral lens angled for wall wash. (-14-C73 Standard).

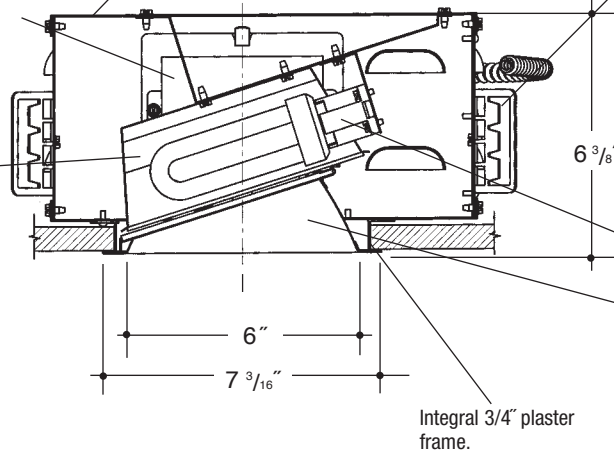
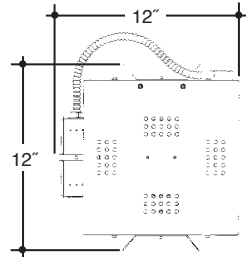

Rough In Kit – 6"x6" Square Horizontal Fluorescent 1-Lamp (Compact Fluorescent Triple or Quad Tube)

Catalog Number **VGS66HFWW1**

VGS66HFWW1

Wattage

Ballast

Voltage

Options

- 57W MAX. DT/E
- 42W PLT
- 32W PLT
- 26W DTT, PLT
- 18W DTT, PLT

- E
- DA
- DL

- 1
- 2
- 3
- 4

EM*

Ballast

- E Electronic (4 Pin Lamp)
- DA Dimming - Advance Mark X (4 Pin Lamp)
- DL Dimming - Lutron Ecosystem (4 Pin Lamp)

Voltage

- 1 120 Volts
- 2 277 Volts
- 3 347 Volts (Electronic Ballast Only)
- 4 208 Volts

Options ▲

- EM* Emergency Battery
- * (TOP COVER REMOVABLE FROM BELOW FOR EM ACCESS)

Electronic Multi-Tap Ballast 120/277V Factory Standard

Finishing Kit – 6"x6" Square Horizontal Spread Lens Wall Wash Reflector

Catalog Number **VGS6637**

VGS6637

Lens

Finish

Options

- 14 C73 (Standard)
- FRO FROSTED

- SCL
- SGC
- ECL

PF

Finish (Factory Standard)

- SCL Specular Clear "Alzak" with White Flange
- SGC Soft Glow Clear "Alzak" (Semi-Spec) with White Flange
- ECL Etched Clear "Alzak" (Haze) with White Flange

Options ▲

- PF High Polished Flange

Features

Manufactured and Listed to UL 1598, ETL and CSA standards.
Suitable for Damp Locations
Wet location under covered ceiling



▲ See Options and Finishes pages for a list of additional finishes and equipment.

Vantage reserves the right to change components, finishes or design details in any manner which does not alter the installed appearance or reduce performance and intended function.

76 Community Avenue Plainfield, CT 06374
voice (860) 564.4512 fax (860) 564.4854
www.vantageitg.com

12/11



VANTAGE