

Job Name \_\_\_\_\_

Type \_\_\_\_\_

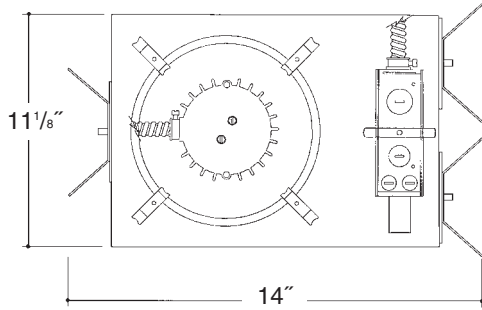

## 5" SHALLOW OPEN WALL WASH INCANDESCENT

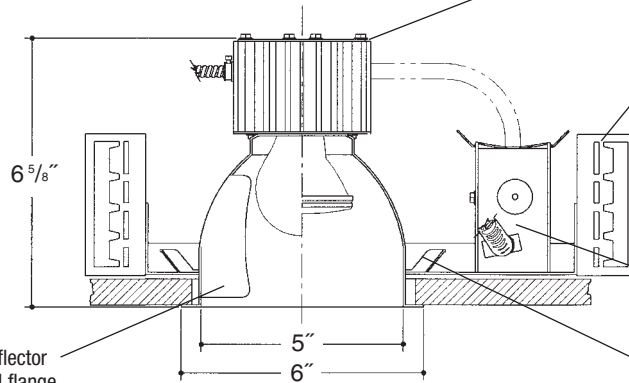

Extruded aluminum heat sink socket cup with Zinc plated steel hardware and spring steel clips for fast assembly. *UL Listed* medium base porcelain socket, with nickel plated brass screw shell.

Adjustable height electrogalvanized plated steel mounting ears with cutouts for various mounting methods. Standard bars (included) are innovative and incorporate rigid formed cross sections, joint positioning tabs, integral nails, auxiliary nailholes, T-Bar slots and holes for locking bars to T-Bar using #8 self-tapping screws (by others). Bars extend 14"-24". Ears will also accept Caddy Bar #520 for fast installation in T-Bar ceilings, bars extend 27".

Heavy gauge electrogalvanized steel junction box, prewired and grounded. Listed for through branch circuit wiring. Thermal cutout provided.

Electrogalvanized plated steel frame with spring steel reflector clips for fast assembly of reflector.

Heavy gauge spun aluminum reflector with self trimming white painted flange. Soft Finish treatment creates wall wash. Polished Flange available.

### Rough in Kit – 5" Incandescent (100W A19; 75W PAR30; 50W PAR20; 75W PAR16)

Catalog Number **A5INC**

**A5INC**

**Wattage**

100W MAX. A19  
75W PAR 30❖❖  
50W PAR20  
75W PAR16

**Voltage**

120

**Options**

277V SD  
R  
PR

Options ▲

**277V SD**

**R**

**PR**

Step Down Transformer 277V to 120V  
Remodeler  
Plaster Ring

❖❖ Long Neck Only

### Finishing Kit – 5" Incandescent Shallow Open Reflector Downlight Wall Washer

Catalog Number **5310**

**5310**

**Finish**

SCL  
SGO

**Options**

PF  
GSK

Finish (Factory Standard)

**SCL**

**SGO**

Specular Clear "Alzak" Reflector with White Flange  
Specular Gold "Alzak" Reflector with White Flange

Options ▲

**PF**

**GSK**

High Polished Flange  
Neoprene Foam Single Gasketing

#### Features

Manufactured and Listed to UL 1598, ETL and CSA standards.  
Suitable for Damp Locations  
Wet location under covered ceiling



▲ See Options and Finishes pages for a list of additional finishes and equipment.

Vantage reserves the right to change components, finishes or design details in any manner which does not alter the installed appearance or reduce performance and intended function.

05/07

76 Community Avenue Plainfield, CT 06374  
voice (860)564.4512 fax (860)564.4854  
www.vantageltg.com

Vantage



Luminaires