

Architectural Pendants Lights

Job Name _____

Type _____

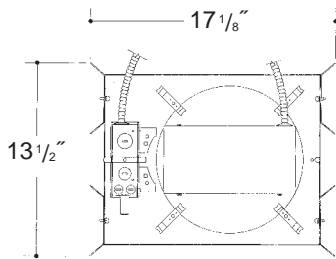

12" OPEN OR BAFFLED INDUCTION LOAD

The Philips QL Induction lamp system is UL, FCC and CSA approved. System consists of lamp (supplied with fixture), power coupler and high frequency generator. Lamp positioned for maximum light output with minimal glare and smooth even illumination.

Heavy gauge electrogalvanized steel junction box, prewired and grounded with easy access from below. Listed for through branch circuit wiring. Thermal cutoff provided.

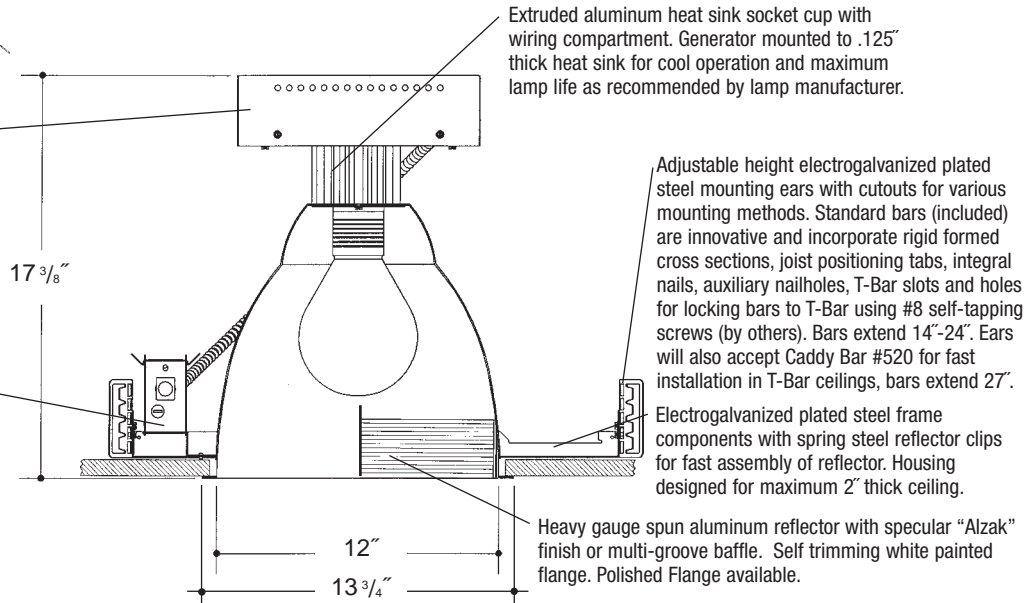

Extruded aluminum heat sink socket cup with wiring compartment. Generator mounted to .125" thick heat sink for cool operation and maximum lamp life as recommended by lamp manufacturer.

Adjustable height electrogalvanized plated steel mounting ears with cutouts for various mounting methods. Standard bars (included) are innovative and incorporate rigid formed cross sections, joist positioning tabs, integral nails, auxiliary nailholes, T-Bar slots and holes for locking bars to T-Bar using #8 self-tapping screws (by others). Bars extend 14"-24". Ears will also accept Caddy Bar #520 for fast installation in T-Bar ceilings, bars extend 27".

Electrogalvanized plated steel frame components with spring steel reflector clips for fast assembly of reflector. Housing designed for maximum 2" thick ceiling.

Heavy gauge spun aluminum reflector with specular "Alzak" finish or multi-groove baffle. Self trimming white painted flange. Polished Flange available.

Rough in Kit – 12" Induction Load (165W, 85W or 55W Philips QL Induction Lamp System).

Catalog Number **AQL12**

AQL12	Wattage	Generator	Voltage	Options
	165W* MAX 85W 55W	E	1 2	R

Generator	
E	Electronic
Voltage	
1	120 Volts
2	277 Volts
Options ▲	
R	Remodeler

* 165W Available in 277V only
Philips QL Induction Lamp included 3000°K standard

Finishing Kit – 12" Induction Open or Open Baffled Reflector

Catalog Number _____

	Finish	Options
12000 Open	SCL SGO	PF
12050 Open Baffled	SCL/BL SGO/BL SCL/WH SGO/WH	

Finish (Factory Standard)

SCL	Specular Clear "Alzak" with White Flange
SGO	Specular Gold "Alzak" with White Flange
SCL/BL	Specular Clear "Alzak" with White Flange and Black Baffle
SGO/BL	Specular Gold "Alzak" with White Flange and Black Baffle
SCL/WH	Specular Clear "Alzak" with White Flange and White Baffle
SGO/WH	Specular Gold "Alzak" with White Flange and White Baffle

Options ▲	
PF	High Polished Flange

Features

Manufactured and Listed to UL 1598, ETL and CSA standards.
Suitable for Damp Locations
Wet location under covered ceiling



▲ See Options and Finishes pages for a list of additional finishes and equipment.

Vantage reserves the right to change components, finishes or design details in any manner which does not alter the installed appearance or reduce performance and intended function.

Vantage

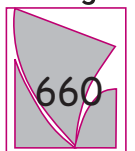

Luminaires

76 Community Avenue Plainfield, CT 06374
voice (860) 564.4512 fax (860) 564.4854
www.vantageitg.com

07/07