

Job Name _____

Type _____

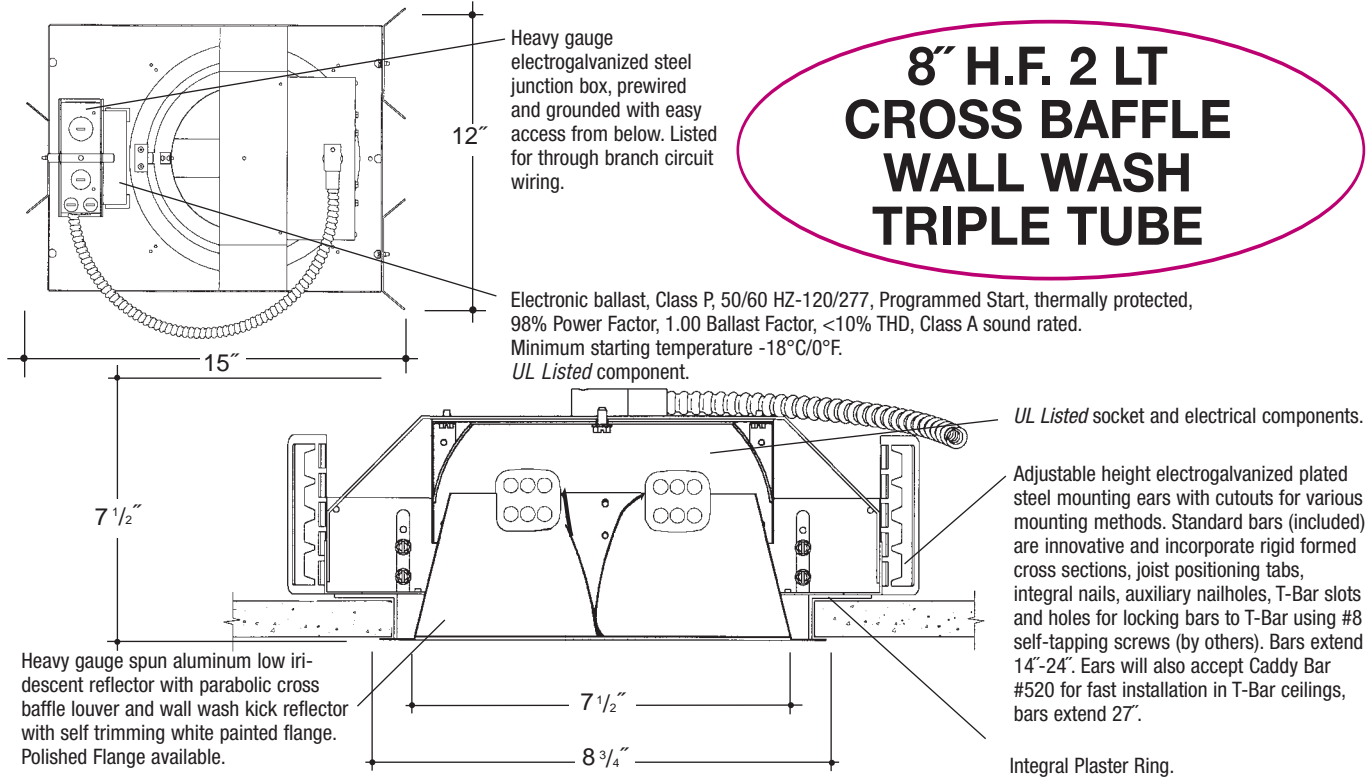

**8" H.F. 2 LT
CROSS BAFFLE
WALL WASH
TRIPLE TUBE**

Rough in Kit – 8" Horizontal Fluorescent 2-Lamp (Compact Fluorescent Triple Tube)

Catalog Number **ASL8HF2**

ASL8HF2

Wattage

Ballast

Voltage

Options

42W MAX. PLT
32W PLT
26W PLT
18W PLT

E
DA
DL

1
2
3
4

EM
F

Ballast		
E	Electronic	(4 Pin Lamp)
DA	Dimming - Advance Mark X	(4 Pin Lamp)
DL	Dimming - Lutron	(4 Pin Lamp)
Voltage		
1	120 Volts	
2	277 Volts	
3	347 Volts (Electronic Ballast only)	
4	208 Volts (Electronic Ballast Only)	
Options ▲		
EM	Emergency Battery	
F	Fused	

Electronic Multi-Tap Ballast 120V Thru 277V Factory Standard

Finishing Kit – 8" Horizontal Fluorescent Shallow Parabolic Cross Baffle Louver and Wall Washer

Catalog Number **AS8655-WW**

AS8655-WW

Finish

Options

SCL
SGO
WHT

PF

Finish (Factory Standard)

SCL Specular Clear "Alzak" with White Flange
SGO Specular Gold "Alzak" with White Flange
WHT White Reflector with White Flange

Options ▲

PF High Polished Flange

Features

Manufactured and Listed to UL 1598, ETL and CSA standards.
Suitable for Damp Locations
Wet location under covered ceiling



▲ See Options and Finishes pages for a list of additional finishes and equipment.

Vantage reserves the right to change components, finishes or design details in any manner which does not alter the installed appearance or reduce performance and intended function.

Vantage

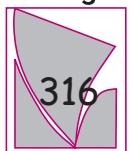

Luminaires

76 Community Avenue Plainfield, CT 06374
voice (860) 564.4512 fax (860) 564.4854
www.vantageitg.com

09/07