

Job Name _____

Type _____

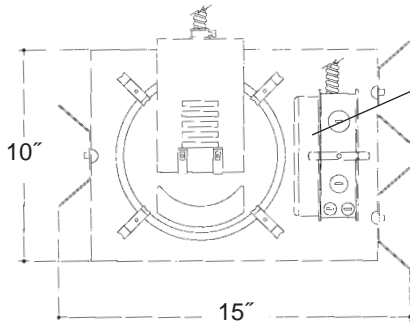

Electronic ballast, Class P, 50/60 HZ-120/277, Programmed Start, thermally protected, 98% Power Factor, 1.00 Ballast Factor, <10% THD, Class A sound rated. Minimum starting temperature -18°C/0°F.
Magnetic ballast, High Power Factor, thermally protected, minimum starting temperature 10°C/50°F.
UL Listed component.

8" H.F. SPREAD LENS WALL WASH

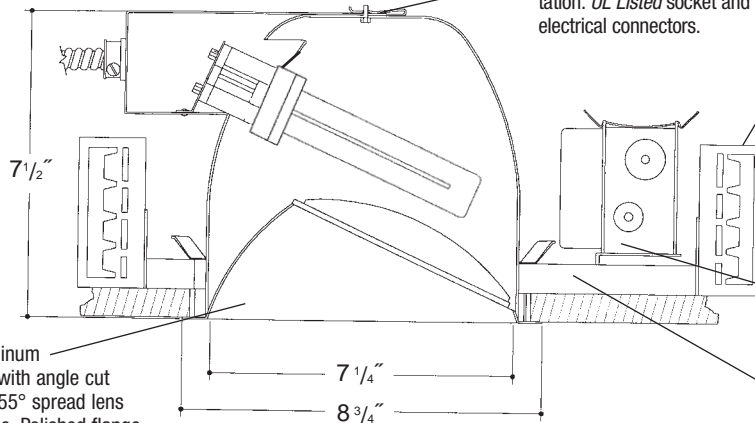

Heavy gauge spun aluminum low iridescent reflector with angle cut cone and wall washing 55° spread lens with white painted flange. Polished flange available. Safety chain provided.

Aluminum socket housing with zinc plated steel quick assembly hardware. Socket angled for proper lamp orientation. *UL Listed* socket and electrical connectors.

Adjustable height electrogalvanized plated steel mounting ears with cutouts for various mounting methods. Standard bars (included) are innovative and incorporate rigid formed cross sections, joist positioning tabs, integral nails, auxiliary nailholes, T-Bar slots and holes for locking bars to T-Bar using #8 self-tapping screws (by others). Bars extend 14"-24". Ears will also accept Caddy Bar #520 for fast installation in T-Bar ceilings, bars extend 27".

Heavy gauge electrogalvanized steel junction box, prewired and grounded with easy access from below, listed for through branch circuit wiring.

Electrogalvanized plated steel frame.

Rough in Kit – 8" Angled Horizontal Fluorescent 2-Lamp (Compact Fluorescent Twin or Quad Tube)

Catalog Number **A8AHF2** _____

A8AHF2

Wattage

Ballast

Voltage

Options

26W MAX. DTT
18W DTT
13*W TT, DTT

E
H
DA
DL

1
2
3
4

EM
F
R
PR

Ballast		
E	Electronic	(4 Pin Lamp)
H	High Power Factor	(2 Pin Lamp)
DA	Dimming - Advance Mark X	(4 Pin Lamp)
DL	Dimming - Lutron	(4 Pin Lamp)
*	13 Watt Advance Mark VII Only	
Voltage		
1	120 Volts	
2	277 Volts	
3	347 Volts (Electronic Ballast only)	
4	208 Volts (Electronic Ballast Only)	
Options ▲		
EM	Emergency Battery	
F	Fused	
R	Remodeler	
PR	Plaster Ring	

1-Lamp – Replace **A8AHF2** with **A8AHF1**

Electronic Multi-Tap Ballast 120V Thru 277V Factory Standard

Finishing Kit – 8" Horizontal Fluorescent Angle Cut "Alzak" Cone 55° Spread Lens Wall Washer

Catalog Number **8637** _____

8637

Finish

Options

SCL
SGO
WHT

PF

Finish (Factory Standard)

SCL Specular Clear "Alzak" with White Flange
SGO Specular Gold "Alzak" with White Flange
WHT White Reflector with White Flange

Options ▲

PF High Polished Flange

Features

Manufactured and Listed to UL 1598, ETL and CSA standards.
Suitable for Damp Locations
Wet location under covered ceiling



▲ See Options and Finishes pages for a list of additional finishes and equipment.

Vantage reserves the right to change components, finishes or design details in any manner which does not alter the installed appearance or reduce performance and intended function.

Vantage

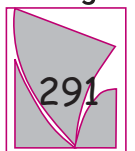

76 Community Avenue Plainfield, CT 06374
voice (860) 564.4512 fax (860) 564.4854
www.vantageitg.com

06/07

Luminaires