

A r c h i t e c t u r a l G r a d e

Job Name _____

Type _____

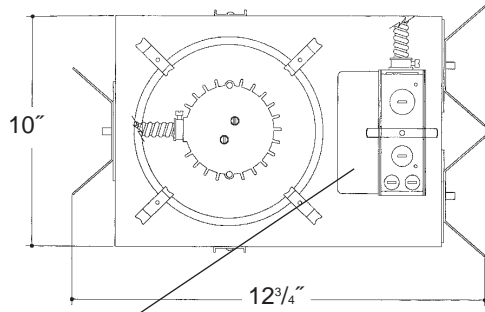

6" V.F. 1 LT OPEN WALL WASH

Electronic ballast, Class P, 50/60 HZ-120/277, Programmed Start, thermally protected, 98% Power Factor, 1.00 Ballast Factor, <10% THD, Class A sound rated. Minimum starting temperature -18°C/0°F.
Magnetic ballast, High Power Factor, thermally protected, minimum starting temperature 10°C/50°F.
UL Listed component.

Heavy gauge spun aluminum low iridescent reflector with self trimming white painted flange. Aluminum wall washing kicker plate in a bright dip clear finish. Polished Flange available.

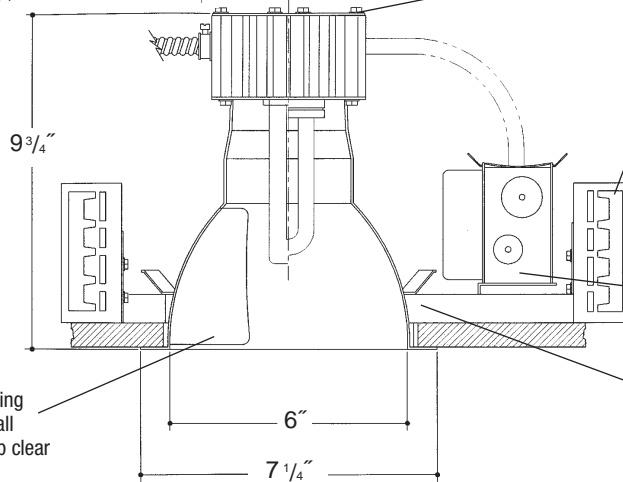

Aluminum heat sink socket cup with Zinc plated steel hardware and spring steel clips for fast assembly. *UL Listed* socket.

Adjustable height electrogalvanized plated steel mounting ears with cutouts for various mounting methods. Standard bars (included) are innovative and incorporate rigid formed cross sections, joist positioning tabs, integral nails, auxiliary nailholes, T-Bar slots and holes for locking bars to T-Bar using #8 self-tapping screws (by others). Bars extend 14"-24". Ears will also accept Caddy Bar #520 for fast installation in T-Bar ceilings, bars extend 27".

Heavy gauge electrogalvanized steel junction box, prewired and grounded with easy access from below, listed for through branch circuit wiring.

Electrogalvanized plated steel frame.

Rough in Kit – 6" Vertical Fluorescent 1-Lamp (Compact Fluorescent Twin, Quad or Triple Tube)

Catalog Number **A6VF1** _____

| A6VF1 | Wattage | Ballast | Voltage | Options |
|--------------|--------------|---------|---------|---------|
| | 42W MAX. PLT | E | 1 | EM |
| | 32W PLT | H | 2 | F |
| | 26W DTT, PLT | DA | 3 | R |
| | 18W DTT, PLT | DL | 4 | PR |
| | 13*W TT, DTT | | | EMI |

| Ballast | |
|------------|--|
| E | Electronic (4 Pin Lamp) |
| H | High Power Factor (2 Pin Lamp) |
| DA | Dimming - Advance Mark X (4 Pin Lamp) |
| DL | Dimming - Lutron (4 Pin Lamp) |
| * | 13W Advance Mark VII Only |
| Voltage | |
| 1 | 120 Volts |
| 2 | 277 Volts |
| 3 | 347 Volts (Electronic Ballast Only) |
| 4 | 208 Volts (Electronic Ballast Only) |
| Options ▲ | |
| EM | Emergency Battery |
| F | Fused |
| R | Remodeler |
| PR | Plaster Ring |
| EMI | Internal Mounted Emergency Test Switch |

2-Lamp Not Available in Triple Tube

2-Lamp – Replace A6VF1 with A6VF2

Electronic Multi-Tap Ballast 120V Thru 277V Factory Standard

Finishing Kit – 6" Vertical Fluorescent Downlight Wall Washer

Catalog Number **6102** _____

| 6102 | Finish | Options |
|-------------|--------|---------|
| | SCL | PF |
| | SGO | |

| Finish (Factory Standard) | |
|---------------------------|--|
| SCL | Specular Clear "Alzak" with White Flange |
| SGO | Specular Gold "Alzak" with White Flange |
| Options ▲ | |
| PF | High Polished Flange |

Features

Manufactured and Listed to UL 1598, ETL and CSA standards.
Suitable for Damp Locations
Wet location under covered ceiling



▲ See Options and Finishes pages for a list of additional finishes and equipment.

Vantage reserves the right to change components, finishes or design details in any manner which does not alter the installed appearance or reduce performance and intended function.

06/07

76 Community Avenue Plainfield, CT 06374
voice (860)564.4512 fax (860)564.4854
www.vantageitg.com

Vantage

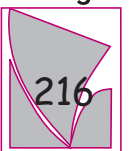

Luminaires